



UNS-F Dual Channel Fused PVS-30



FOR MORE INFO CONTACT:

KnightVisionSales@knightarmco.com

Phone: 321.607.9900

Fax: 321.268.1498

701 Columbia Blvd

Titusville, Florida 32780

The UNS-F clip-on weapon sight is a combination of the Knight's Armament Company very successful AN/PVS-30 and a high resolution 12 micron detector resulting in a Fused Clip on Weapon Sight. (UNS-F) The UNS-F provides the user with a combination of Image intensified and thermal images in the same system. Where the user can switch from Thermal to Night Vision or combine both with an image that has the thermal information (full thermal or outline) in the image intensified field of view. The image intensified Channel consists of an 18mm Anvis tube (FOM restriction may apply for export) and 120MM Refractive Telephoto objective with the same performance characteristics as the PVS-30. The thermal channel is a 320 x 240, 12 micron detector using an approx. 40mm Focal length IR refractive lens of fixed focus. The thermal is used to indicate targets in the image intensified scene. Boresight Accuracy Retention (BAR) as well as a host of Knight's Armament clip on weapon sight attributes are included in the UNS-F.

© Knight's Armament Company. Printed and designed in the United States of America. No part of this publication may be reproduced without the prior written consent of Knight's Armament Company. Products are subject to change without notice. Knight's Armament Company is an ISO 9001:2008 Certified Company. The products, product specifications, nomenclature, and availability of all items featured in this document are subject to change at the discretion of Knight's Armament Company. Some products featured here may be photographed with optional accessories UNS™ name is a registered trademark of Knight's Armament Company, Trademark # 76516796.

ITAR STATEMENT:

These items are firearm or defense related goods governed regulated by U.S. Department of State International Traffic in Arms Regulations (22CFR, Parts 120-130) and therefore require an Export License to be transported outside of the United States.

CAGE CODE: 1S002

NOTICE: PROPRIETARY DATA OBLIGATION

THIS DOCUMENT CONTAINS UNPUBLISHED PROPRIETARY INFORMATION AND TRADE SECRETS OF Knight's Armament Company and is the sole and exclusive property of Knight's Armament Company. By accepting possession of this document, the recipient agrees to keep confidential this document and the information contained herein except as authorized in writing by Knight's Armament Company; and to safe keep this document and return it to Knight's Armament Company upon demand or when it is no longer needed.

Cage Code: 1S002, DUNS No. 05-403-8138, TIN: 59-1230657

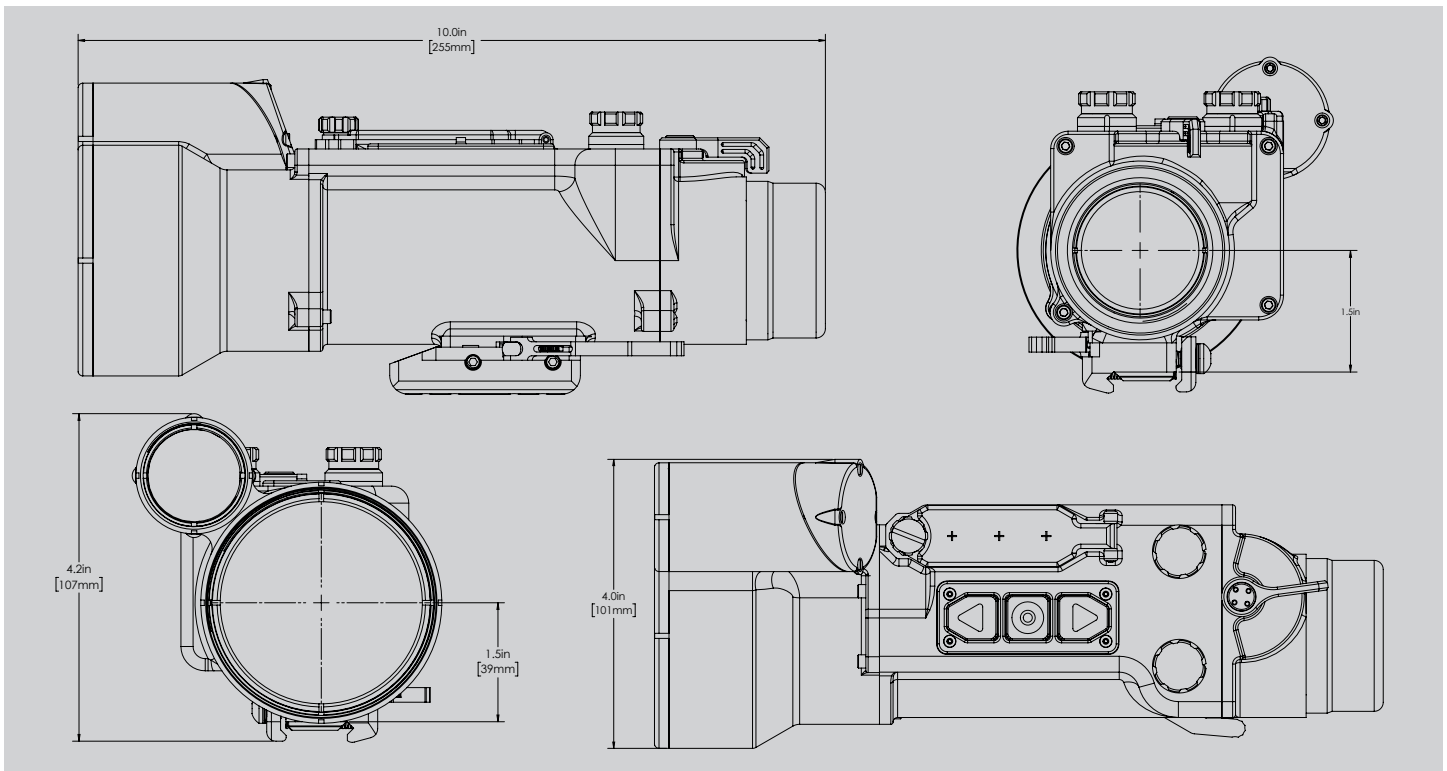

SPECIFICATIONS

SIZE:	10" (255mm) long, 4.2" (107mm) high, 1.5" (38mm) to optical center
WEIGHT:	3.75 lbs. (1.7 kg)
FINISH:	Flat Black Matte or Desert Sand Brown, Corrosion Resistant
CONTROLS:	On/Off Gain Control Knob, Both Channels, Rear Focus Lever
POWER:	Three AA Lithium Batteries
BATTERY LIFE:	>8 hours 0° C
MOUNT:	KAC 26597 for Quick Attach /Detach to MII-STD-1913 Rail or equivalent mounting surface
FOV:	9° (Image Intensified) 6° (Thermal)
WATERPROOF:	3 ft. for 4 hours

OPTICAL CHARACTERISTICS

Lens Design:	120MM Refractive Telephoto Lens Image Intensified / 50MM Refractive Thermal
Magnification:	Unity
Focus Range:	20 Meters to Infinity
Bore sight:	Patented (US Patent 7,142,357) alignment technology proven in thousands of delivered sniper sights
Sensors:	ANVIS 18 MM configuration Image Intensified Tube 320 x 240, 12 Micron Thermal Detector, 15 (or 9.6) Micron eMagin Display

PERFORMANCE CHARACTERISTICS

Range:	Recognize a Standing Man under Starlight: >800 m
	Recognize a Standing Man under 1/4 Moon: >1000 m
	Recognize a Vehicle Under Starlight >1000 m
	Recognize a Vehicle under 1/4 Moon >1500m
Bore Sight:	<0.5 MOA
Bore sight retention:	< 0.5 MOA
Weapons Certification:	Tested for use on weapons up to and including .50 caliber rifles
Cheek Weld:	Unchanged
Eye Relief:	Unchanged
Bullet Impact:	Unchanged

NOTICE: PROPRIETARY DATA OBLIGATION

THIS DOCUMENT CONTAINS UNPUBLISHED PROPRIETARY INFORMATION AND TRADE SECRETS OF Knight's Armament Company and is the sole and exclusive property of Knight's Armament Company. By accepting possession of this document, the recipient agrees to keep confidential this document and the information contained herein except as authorized in writing by Knight's Armament Company; and to safe keep this document and return it to Knight's Armament Company upon demand or when it is no longer needed.

Cage Code: 15002, DUNS No. 05-403-8138, TIN: 59-1230657