



PROUDLY SUPPLIED TO THE US MILITARY  
**KNIGHT  
VISION™**

## **UNS-LR A2 (UNIVERSAL NIGHT SIGHT LONG RANGE)**



### **FOR MORE INFO CONTACT:**

[KnightVisionSales@knightarmco.com](mailto:KnightVisionSales@knightarmco.com)

Phone: 321.607.9900

Fax: 321.268.1498

701 Columbia Blvd.

Titusville, Florida 32780

The UNS-LR A2™ clip-on Weapon Sight (WS) is a product improved version of the AN/PVS-30 it adds the latest high performance Gen 3 light intensification night vision to most rifles and day scopes by attaching to the picatinny rail. This product is appropriate for front line long range rifles. The Knight Vision patented technology as well as the extended focus level makes the product universal easy to use from the shooting position and assures the accuracy of your range-tested day scope boresight will not be degraded. When the UNS-LR A2™ is added in front, your existing optic, eye relief, and cheek weld are undisturbed. The refractive lens provides high performance light collection in a light weight design. Knight Vision patented Single Interchangeable Battery (SIB)® allows use of either CR123 or AA single cells, with a battery life exceeding 24 hours while the shooter remains in shooting position. The highly efficient power circuit allows use of depleted flashlight batteries to provide several hours of operation. Single Interchangeable Battery (SIB)® U.S. Patent No. 7,576,516.

© Knight's Armament Company. Printed and designed in the United States of America. No part of this publication may be reproduced without the prior written consent of Knight's Armament Company. Products are subject to change without notice. Knight's Armament Company is an ISO 9001 Certified Company. The products, product specifications, nomenclature, and availability of all items featured in this document are subject to change at the discretion of Knight's Armament Company. Products may be photographed with optional accessories. Some products are available in other colors.

ITAR STATEMENT: These item(s) are firearm or defense related goods. Export of the goods described herein is strictly prohibited without a valid export license issued by the US Department of State, Directorate of Defense Trade Controls as prescribed in International Traffic in Arms Regulation (ITAR), CODE OF FEDERAL REGULATIONS, Title 22, Parts 120-130. CAGE Code: 15002

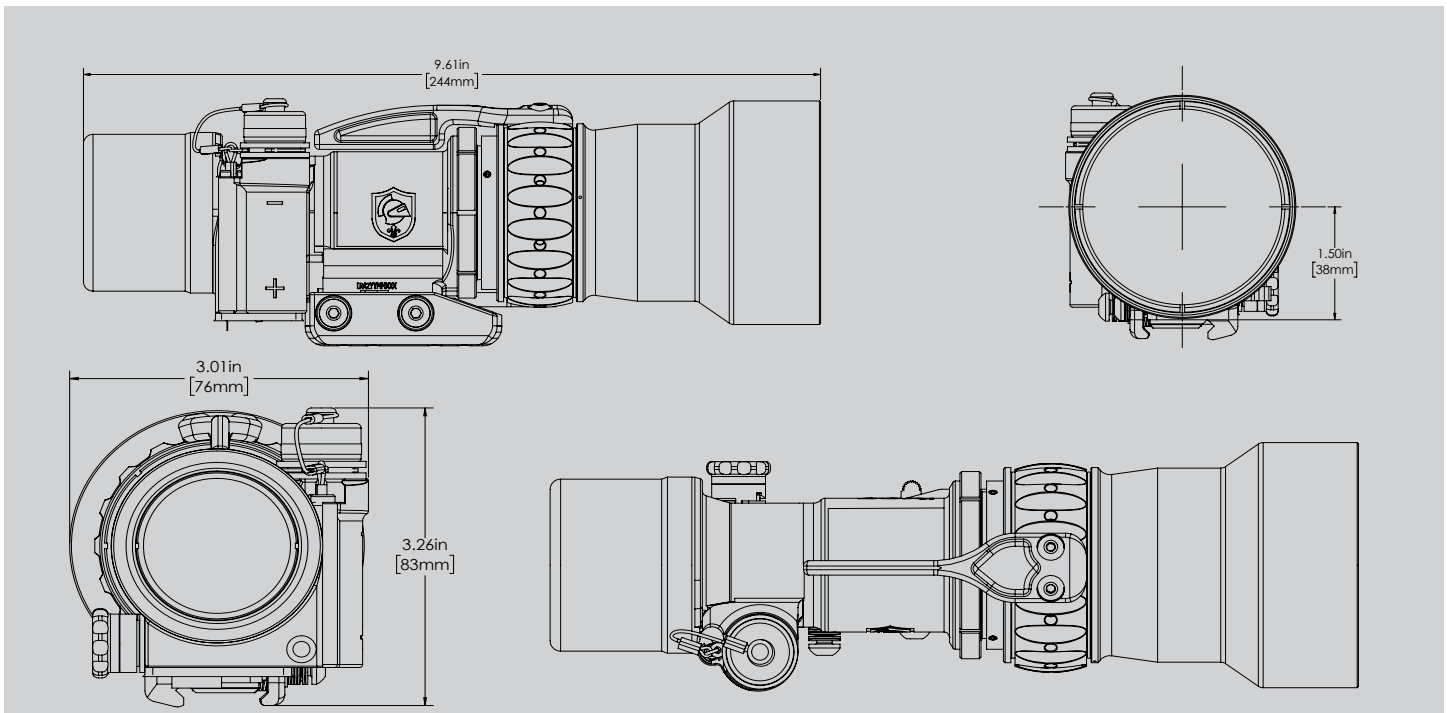

### SPECIFICATIONS (Preliminary)

**SIZE:** 9.61" long (244mm) 3.01" (76mm) high, 1.5"(38mm) to optical centerline  
**WEIGHT:** 2.9 lbs. (1.31 kg)  
**FINISH:** Flat Black Matte or Desert Sand Brown, Corrosion Resistant  
**CONTROLS:** Pull On/Off gain knob  
 Focus knob  
**POWER:** One standard AA battery, or one DL123 battery  
**BATTERY LIFE:** AA battery exceeds 24 hours, DL123 battery exceeds 36 hours  
**MOUNT:** KAC mount or quick attach / detach to MIL-STD-1913 rail or equivalent  
**FIELD OF VIEW (FOV):** 9°  
**WATERPROOF:** 3 ft. for 4 hours

### OPTICAL CHARACTERISTICS

**Lens Design:** 120mm Refractive Telephoto  
**Magnification:** 1X (unity)  
**Focus Range:** 20 Meters to Infinity  
**Image Intensification:** ANVIS 18mm Configuration Image Intensified Tubes FOM Restrictions For Export May Apply

### PERFORMANCE CHARACTERISTICS

**Range:** Recognize a Standing Man under Starlight: > 800 m  
 Recognize a Standing Man under 1/4 Moon: >1000 m  
 Recognize a Vehicle Under Starlight >1000 m  
 Recognize a Vehicle under 1/4 Moon >1500 m  
**Bore Sight:** Factory Bore Sight to within .5 MOA of alignment to the day scope point of impact  
**Bore sight retention:** < 0.5 MOA over 300 rounds, 300 WIN MAG firing Schedule  
**Weapons Certification:** Tested for use on weapons up to and including .50 caliber rifles  
**Cheek Weld:** Unchanged  
**Eye Relief:** Unchanged  
**Bullet Impact:** Unchanged

© Knight's Armament Company. Printed and designed in the United States of America. No part of this publication may be reproduced without the prior written consent of Knight's Armament Company. Products are subject to change without notice. Knight's Armament Company is an ISO 9001 Certified Company. The products, product specifications, nomenclature, and availability of all items featured in this document are subject to change at the discretion of Knight's Armament Company. Products may be photographed with optional accessories. Some products are available in other colors.

ITAR STATEMENT: These item(s) are firearm or defense related goods. Export of the goods described herein is strictly prohibited without a valid export license issued by the US Department of State, Directorate of Defense Trade Controls as prescribed in International Traffic in Arms Regulation (ITAR), CODE OF FEDERAL REGULATIONS, Title 22, Parts 120-130. CAGE Code: 15002