



INST-00105

DEC. 2012 KAC Supplement to:
 ARMY TM 9-1005-319-23&P
 AIR FORCE TO 11W3-5-542

CLOCKING INSTRUCTIONS FOR URX SHIM SET PN 30229

CLOCKING INSTRUCTIONS

1. Assemble using the black shim (required) and add shims as necessary to achieve hand tightening at approximately position "A."
2. Apply torque between 60-140 ft. lbs. from position "A" to reach position "B."

Note: Adjust the amount of shims as needed to reach specified torque as the top rail reaches Top Dead Center (TDC) at position "B."

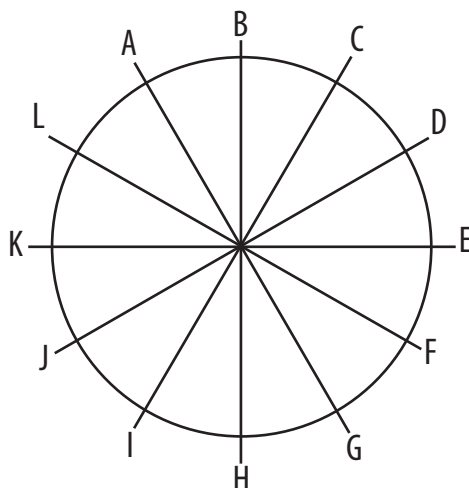

AS VIEW FROM MUZZLE

Hand Tightens at	Add	Suggested Shims
A	.000	Black Shim
B	.005	.005 Black Shim
C	.009	.005 + .002 + .002 Black Shim
D	.014	.010 + .002 + .002 Black Shim
E	.018	.016 + .002 Black Shim
F	.023	.016 + .005 + .002 Black Shim
G	.027	.025 + .002 Black Shim
H	.032	.025 + .005 + .002 Black Shim
I	.037	.025 + .010 + .002 Black Shim
J	.041	.025 + .016 Black Shim
K	.045	.025 + .016 + .002 + .002 Black Shim
L	.050	.025 + .016 + .002 + .002 Black Shim

Shim Identification	
Shim Thickness	Number of Notches
0.002	0
0.005	1
0.010	2
0.016	3
0.025	4

EXAMPLE OF POSITION A

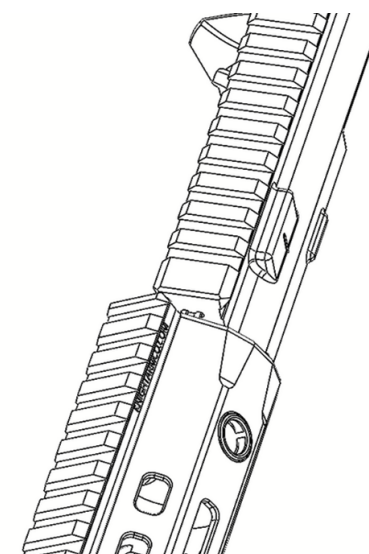

Note:

30° of rotation requires +/- .004" and 60° requires .008".

In example A, add .008 to the .025 thickness (.033" total) to position at 11 o'clock hand tight. Do the math: .025+.005+.002=.032".

Use .032 and note torque at TDC. If less than 60 ft. lbs., add one more .002 to the shims for a total of .034" and re-torque as required: 60-140 ft. lbs. is optimal.



KAC

KNIGHTS ARMAMENT

phone (321) 607-9900
fax (321) 268-1498
701 Columbia Blvd., Titusville, FL 32780
www.KnightArmCo.com
CAGE Code: 1S002

ITAR
International Traffic in Arms Regulations

RESTRICTED EXPORT. The item(s) are firearm or defense related goods governed by U.S. Government International Traffic in Arms Regulations 22 CFR, ITAR Parts 120-130 and therefore require an Export License issued by the U.S. Department of State to be subsequently transported outside of the United States. These items may not be transferred, transshipped on a non-continuous voyage, or otherwise be disposed of in any other country, either in their original form or after being incorporated into other end items. The International Traffic in Arms Regulations (ITAR) is a set of United States government regulations that control the export of defense-related articles and services on the United States Munitions List. These regulations implement the provisions of the Arms Export Control Act, and are described in Title 22 (Foreign Relations), Chapter (Department of State), Sub chapter M of the Code of Federal Regulations.