



ACC-IN-0005
REV 2

FORWARD PISTOL GRIP

The KAC Forward (or Vertical) Pistol Grip consists of three parts: the Grip, the Lock, and the O-Ring Clutch. Before installing Grip to the rail, install 2, 4, 5, or 6-Rib Handguard Panels, as appropriate for your shooting comfort, between the magazine well and the rail position desired for the Grip.

Installation:

1. Loosen Lock counter-clockwise so the Locking Lug is below the view window.
2. Slide Grip onto rail and align the View Window with the rail groove where you want the Grip centered.
3. Rotate Lock clockwise to tighten in selected groove. *Note: Lock is slotted for a coin or key to fully tighten to rail.*

Inspection for Serviceability: Replace unit if Locking Lug is chipped or not well formed. Replace Clutch O-Ring (P/N: 22020) when it fails to keep the Lock tight during firing.

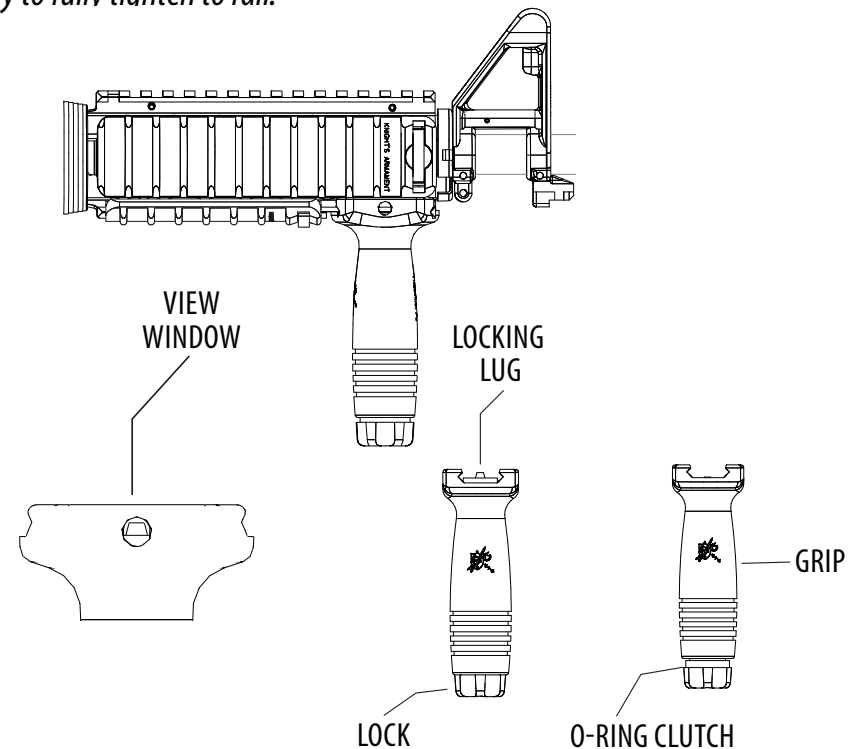



KAC

KNIGHTS ARMAMENT

phone (321) 607-9900
fax (321) 268-1498
701 Columbia Blvd., Titusville, FL 32780
www.KnightArmCo.com
CAGE Code: 1S002

ITAR
International Traffic in Arms Regulations

RESTRICTED EXPORT. The item(s) are firearm or defense related goods governed by U.S. Government International Traffic in Arms Regulations 22 CFR, ITAR Parts 120-130 and therefore require an Export License issued by the U.S. Department of State to be subsequently transported outside of the United States. These items may not be transferred, transshipped on a non-continuous voyage, or otherwise be disposed of in any other country, either in their original form or after being incorporated into other end items. The International Traffic in Arms Regulations (ITAR) is a set of United States government regulations that control the export of defense-related articles and services on the United States Munitions List. These regulations implement the provisions of the Arms Export Control Act, and are described in Title 22 (Foreign Relations), Chapter (Department of State), Sub chapter M of the Code of Federal Regulations.