

KAC BIPOD

1. RAIL MOUNTING

- Press cross bolt and slide onto 1913 rail system.
- Release cross bolt to lock into 1913 slot.

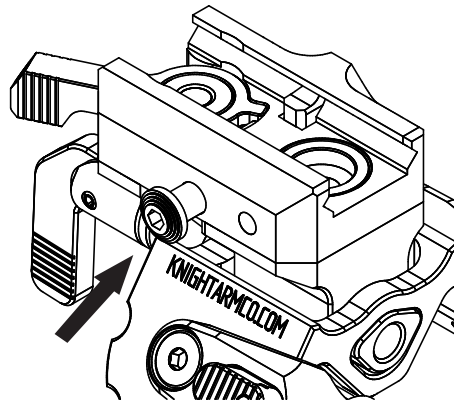

2. LEG ANGLE ADJUSTMENT

- Press leg lock button and rotate leg into one of the six key positions.
- Release button to lock adjustment.

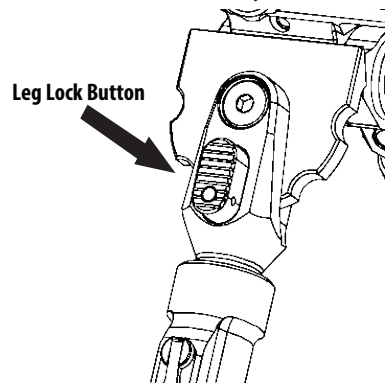

3. LEG LENGTH ADJUSTMENT

- Press leg length button and extend to desired length.
- Release to lock.

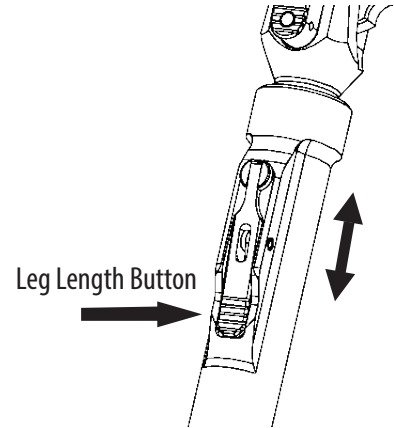

4. PAN ADJUSTMENT

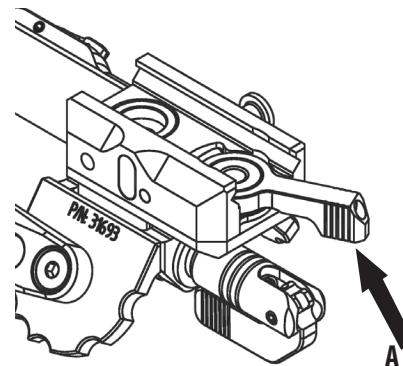

A. Pan Lock Lever

5. CANT ADJUSTMENT

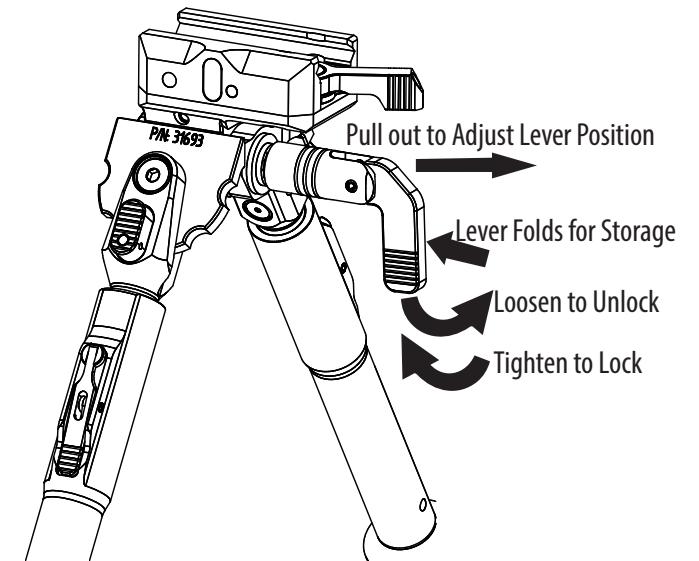

6. FOOT REMOVAL

- Press detent.
- Remove Foot.

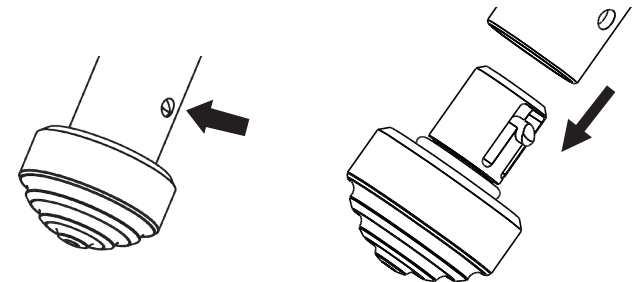



KAC

KNIGHTS ARMAMENT

phone (321) 607-9900
fax (321) 268-1498
701 Columbia Blvd., Titusville, FL 32780
www.KnightArmCo.com
CAGE Code: 1S002

ITAR
International Traffic in Arms Regulations

RESTRICTED EXPORT. The item(s) are firearm or defense related goods governed by U.S. Government International Traffic in Arms Regulations 22 CFR, ITAR Parts 120-130 and therefore require an Export License issued by the U.S. Department of State to be subsequently transported outside of the United States. These items may not be transferred, transshipped on a non-continuous voyage, or otherwise be disposed of in any other country, either in their original form or after being incorporated into other end items. The International Traffic in Arms Regulations (ITAR) is a set of United States government regulations that control the export of defense-related articles and services on the United States Munitions List. These regulations implement the provisions of the Arms Export Control Act, and are described in Title 22 (Foreign Relations), Chapter (Department of State), Sub chapter M of the Code of Federal Regulations.