



NVD-UM-0016

REV 3

UNS LR-A3
Universal Night Sight, Long Range



CAGE Code: 1S002
DUNS No. 05-403-8138
TIN: 59-1230657

phone (321) 607-9900
fax (321) 268-1498
701 Columbia Blvd.
Titusville, FL 32780
www.KnightArmCo.com

OPERATORS MANUAL

TABLE OF CONTENTS

SAFETY SUMMARY	2	3.3 Electrical Principle of Operation	26
General Safety Instructions	2	4. OPERATING INSTRUCTIONS	27
Warnings, Cautions, and Notes	2	4.1 Controls	27
General Safety Precautions	3-6	4.2 Gain/Power Switch	27
1. INTRODUCTION	7	4.3 Focus Ring	28
1.1 General	7	4.4 Operation Under Adverse Conditions	29
1.2 System Description	8-9	4.5 Operation in Dusty or Sandy Conditions	29
1.3 Capabilities	10	4.6 Operation in Rainy or Humid Conditions	29
1.4 Performance Characteristics	11	4.7 Operation In Saltwater Areas	29
1.5 Items Furnished	12-13	5. Handling Instructions	30
1.6 Equipment Required But Not Supplied	14	5.1 Storage	30-31
1.7 Shipping, Handling and Storage	14	6. MAINTENANCE AND SERVICING INSTRUCTIONS	32
1.8 Warranty	15	6.1 Cleaning And Lubrication Instructions	32
2. PREPARATION FOR USE AND INSTALLATION	16	6.2 Non-optical Surfaces	32
2.1 Preparation for Use	16	6.3 Optical Surfaces	32
2.2 Battery Installation	17	6.4 Lubrication	32
2.3 Installation/Mounting	18-19	6.5 Troubleshooting	33
2.4 Adjustment of QD Rail Mount	20-23	6.6 Preparation for Shipment	33
2.5 Installing Shroud Wrap Coupler	24	7. SPARE PARTS LIST	34
3. Principles of Operation	25	7.1 UNS LR-A3 Spare Parts	34
3.1 General	25		
3.2 Optical Principle of Operation	25		

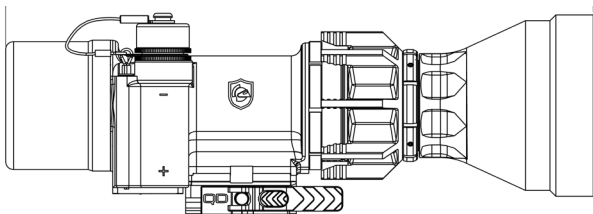

RIGHT SIDE VIEW

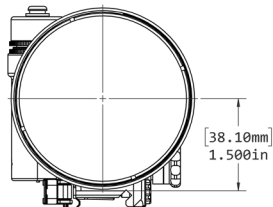

FRONT VIEW

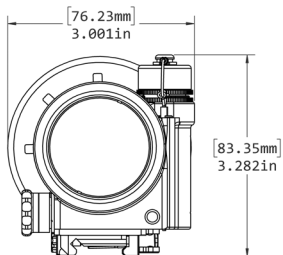

REAR VIEW

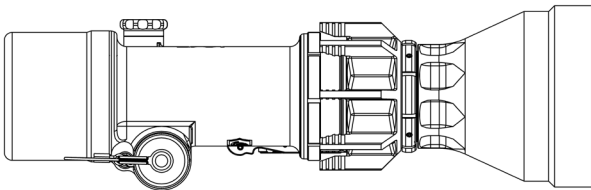

TOP VIEW

SAFETY SUMMARY

General Safety Instructions

This manual describes processes that may cause injury or death to personnel, or damage to equipment if not properly followed. This safety summary includes general safety precautions and instructions that must be understood and applied during operation and maintenance to ensure personnel safety and protection of equipment. Prior to performing any task, the WARNINGS, CAUTIONS, and NOTES included in that task shall be reviewed and understood.

Warnings, Cautions, and Notes

WARNINGS and CAUTIONS are used in this manual to highlight operating or maintenance procedures, practices, conditions or statements that are considered essential to protection of personnel (WARNING) or equipment (CAUTION). WARNINGS and CAUTIONS immediately precede the step or procedure to which they apply. NOTES are used in this manual to highlight operating or maintenance procedures, practices, conditions or statements that are not essential to protection of personnel or equipment. NOTES may precede or follow the step or procedures depending upon the information to be highlighted. The headings used and their definitions are as follows: Warning, Caution and Note.



Highlights an essential operating or maintenance procedure, practice, condition, statement, etc., which, if not strictly observed, could result in injury to or death of personnel or long-term health hazards.



CAUTION



Highlights an essential operating or maintenance procedure, practice, condition, statement, etc., which, if not strictly observed, could result in damage to, or destruction of equipment or loss of mission effectiveness.



NOTE: Highlights an essential operating or maintenance procedure, condition or statement.



GENERAL SAFETY PRECAUTIONS

The following safety precautions of a general nature shall be observed while operating the equipment or performing the procedures in this manual.



WARNING



All batteries should be inspected for bulging prior to use. If a battery shows signs of bulging, corrosion or leakage, do not use. Batteries should be handled in the following manner.

- Do not dispose of in fire.
- Do not short circuit, puncture, or disassemble.
- Return for disposal in accordance with proper disposal instructions.



To avoid physical injury and equipment damage when using the UNS LR-A3 during night operations, carefully read and understand the following precautions:

- The equipment requires some night light (moonlight, starlight, sky glow, etc.) to operate.
The level of performance depends upon the level of light.
- Night light is reduced by passing cloud cover or while operating under trees, in building shadows, etc.
- The equipment is less effective when viewing into shadows and other darkened areas.
- The equipment has degraded function through rain, fog, sleet, snow or smoke.



The UNS LR-A3 is a precision electro-optical instrument and must be handled with care at all times. Read and understand this entire manual before attempting to turn on or operate.

Do not remove the front lens cover in bright light. Exposure of the image intensifier tube in the UNS LR-A3 to bright light for long durations may cause damage.

Do not store the UNS LR-A3 with the batteries installed. Damage can occur from corroded, leaking or improperly stored batteries.

Using the UNS LR-A3 under high light conditions can damage the Image Intensifier Assembly, which permanently lowers performance.

Do not point the UNS LR-A3 at bright lights without the lens cover in place. Remove the lens cover when preparing to use.

The unit cannot be used with the lens cover blocking the objective lens or eyepiece.

Rinse optical surfaces with clean water to remove dirt before wiping with lens tissue. Wiping extremely dirty or sandy optical surfaces could scratch the optical surfaces and permanently damage the lenses.



NOTES:

If the base cannot pivot down onto the rail, the base is adjusted too tight!

If the base is loose on the rail when the lever is fully closed, the base is adjusted too loose!

The factory QD Rail Mount can be adjusted to fit Picatinny rails, manufactured per MIL-STD-1913, or STANAG 4694.

1. INTRODUCTION

1.1 General

This manual provides descriptive information, operating instructions and maintenance procedures for the UNS LR-A3. The high performance unity-power (1X) night vision device allows night operation of any weapon system equipped with a MIL-STD-1913, or STANAG-4694, rail. Mounting options are available for weapons that are not equipped with a MIL-STD 1913 rail in front on the day optic which will provide adequate space for mounting the UNS LR-A3. Any weapon equipped with a Knight's Armament Company Rail Adapter System (RAS) will accommodate the UNS LR-A3.

The UNS LR-A3 primary use is intended to be in conjunction with day optics mounted to weapons as the primary sighting system. The UNS LR-A3 can be mounted forward of the day optic without any adverse effect on the weapon's Point of Aim or Point of Impact. Verify after adjustments of QD Rail Mount and prior to mission.

The UNS LR-A3 does not require any zeroing procedure when installed in front of a day optic. However, the following steps should be taken to ensure optimum picture quality. The controls on the UNS LR-A3 are focus and gain. The day optic, if equipped with a parallax or focus adjustment, should be adjusted to near infinity and parallax free. This allows the day optic to be focused clearly on the back of the image intensifier tube. The focus on the UNS LR-A3 will then be used to adjust the focus of the sight picture.

1.2 System Description

Size	9.44" (240mm) long, 3.00" (76.2mm) wide, 3.28" (83mm) high, 1.50" (38mm) to optical centerline
Weight	with one AA battery and lens cover 2.1lbs (0.95 Kg)
Magnification	1X Unity Sight
Finish	Flat Black Matte or Flat Dark Earth, Corrosion Resistant
Controls	Pull On/Off and Gain Control Switch, Focus Ring
Power	One "AA" size battery or one DL123 battery
Mount	Quick attach/detach, fits the Mil-STD-1913 / STANAG-4694 Rail Configuration
Image Intensifier Tube	High FOM, white or green phosphor, (exportable models available) Tubes manufactured by Elbit USA, L3-Harris, or Photonis (customer specified)
Effective Focal Length (Obj)	120 mm Refractive Telephoto
Objective Focus Continuity	Continually adjustable from approximately 20 meters to infinity via manual control
Bore Sight	Factory bore sight to within .5 MOA of alignment to day scope point of impact
Bore Sight Retention	Maintained within < .5 MOA over a 300 round, 300 WIN MAG firing schedule
Display Brightness	Variable display brightness allows viewing from 105 lux (bright sunshine) to 10-4 lux (total darkness) without inhibiting user's dark-adapted vision.

UNS LR-A3 Configuration

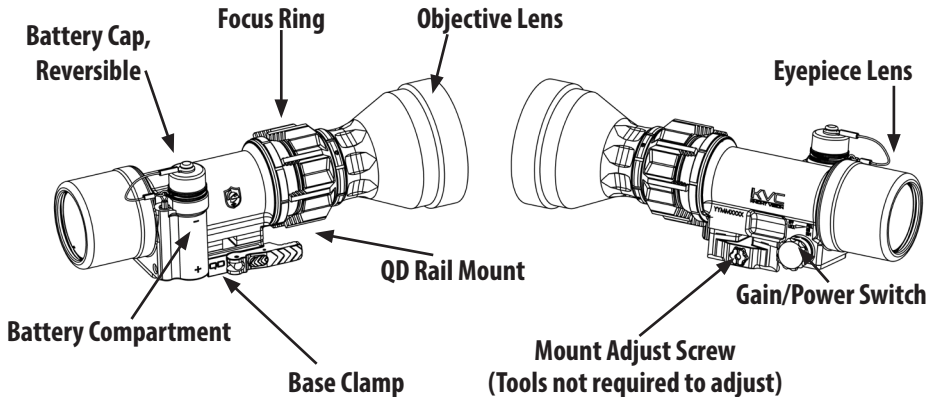

1.3 Capabilities

The UNS LR-A3 is a lighter weight improvement of the AN/PVS-30 Universal Night Sight, Long Range. The UNS LR-A3 adds the latest high performance Gen 3 light intensification night vision to most rifles and day scopes. This product is appropriate for front line long range rifles. The Knight Vision patented technology makes the product universal and assures the accuracy of your range tested day scope boresight will not be degraded. When the UNS LR-A3 is added in front, your existing optic, eye relief, and cheek weld are undisturbed. The refractive lens provides high performance light collection in a light weight design. Knight Vision patented Single Interchangeable Battery (SIB)[®] allows use of either CR123 or AA single cells, with a battery life exceeding 24 hours, and can be changed while you remain in shooting position. The highly efficient power circuit allows use of depleted flashlight batteries to provide several hours of operation. Single Interchangeable Battery (SIB)[®] U.S. Patent No. 7,576,516.

1.4 Performance Characteristics

System Resolution	4.8 Lp/mm minimum using 100% contrast USAF Resolution Chart
Focus Range	20M to infinity adjustment range
Magnification	Unity 1X
Image Intensifier Tube	High FOM, white or green phosphor, (exportable models available) Tubes manufactured by Elbit USA, L3-Harris, or Photonis
Gain Control	On/Off and Gain Control in a single knob
Objective Lens	Refractive Telephoto 120 mm
Exit Pupil	35mm Diameter, Minimum
Bore Sight Deviation	Less than .5 MOA
Bore Sight Repeatability	Less than .5 MOA
Environmental	MIL-STD-810G used as guideline, temperature ranges, saltwater resistance, immersion to 3 feet saltwater pressure
Finish	Flat Black Matte or Flat Dark Earth, Corrosion Resistant
Dimensions	9.44" (240mm) Long, 3.00" (76.2mm) Wide, 3.28" (83mm) High, 1.50" (38mm) height, rail to optical axis centerline
Mounting Options	Any MIL-STD-1913 / STANAG 4694 Rail, with adequate room and clearance forward of the day optic

1.5 Items Furnished

UNS LR-A3 WITH ACCESSORIES PART NUMBER: 115539			
ITEM NO.	PART NO.	DESCRIPTION	QTY
1	114455	UNS LR-A3	1
2	117570	OBJECTIVE COVER, UNS LR-A3	1
3	26546	SHROUD, EYEPIECE	1
4	26188	SHROUD WRAP	1
5	26187	SCOPE POUCH, GEN III, MOLLE	1
6	26572	LENS CLEANING KIT	1
7	NVD-UM-0016	TECHNICAL MANUAL, UNS LR-A3	1
8	23228	WRENCH, HEY KEY, 1-8 IN	1
9	20299	AA BATTERY	1
10	26354	ANTI-REFLECTION ASSY LR	1
11	BW-137-077-062	BOX	1

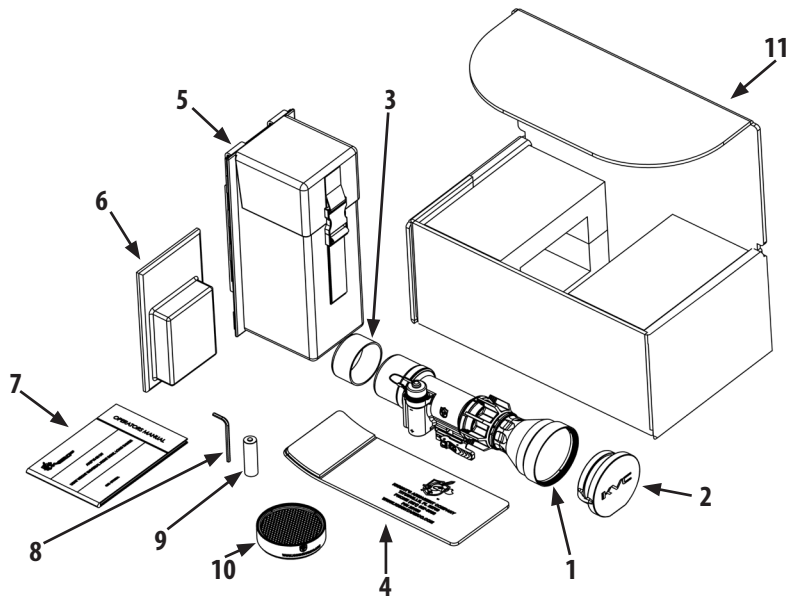

1.6 Equipment Required But Not Supplied

The UNS LR-A3 is equipped to fit on any weapon with a MIL-STD-1913 rail forward of the day optic. In some cases, additional mounting rails must be fitted to the weapon to allow UNS LR-A3 optics mounting.

1.7 Shipping, Handling and Storage

The UNS LR-A3 is a precision electro-optical device and must be handled with care at all times. The UNS LR-A3 should normally be transported and stored in the soft pouch carry case that is provided in the kit or can be purchased separately.

1.8 Warranty

Limited Commercial Warranty

Knight's Armament Company (KAC) warrants the UNS LR-A3 "Knightscope™" against defects due to substandard parts or workmanship for a period of 12 months from date of acceptance (or as stated in Contract). Failed units must be returned to KAC for warranty repairs. If KAC determines, after incoming inspection, that the unit has failed due to misuse or abuse, warranty provisions will not apply. At the customer's request KAC will generate and provide a repair estimate. KAC is not liable for any and all direct or consequential damages that may arise from the misuse or misapplication of this product. For factory service, please contact KAC and obtain a Return Material Authorization (RMA) number prior to return of any equipment.

2. PREPARATION FOR USE AND INSTALLATION

2.1 Preparation for Use

Unpack the UNS LR-A3 from the soft pouch. Install the battery.

ITEM	DESCRIPTION	QTY
1	BATTERY CAP, REVERSIBLE, UNS	1
2	DL 123 BATTERY (OPTIONAL)	1
3	AA BATTERY (OPTIONAL)	1
4	RUBBER COVER, BATTERY CAP	1

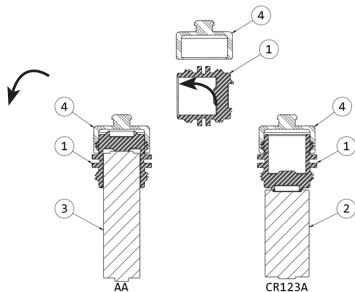

NOTE: The rubber cover for the battery cap can remain on when changing the same type batteries. Only remove the rubber cover for the battery cap when switching battery types.



2.2 Battery Installation (1 Battery)

1. Clear away any debris (dirt, sand, etc.).
2. Unscrew cap counterclockwise to remove battery cap.
3. Replace battery positive contact down. Use extreme care to keep debris out of the battery compartment and battery cap threads.
4. Screw cap clockwise back on.
5. To switch battery types (AA or DL 123), remove the rubber cap cover and turn the reversible battery cap over. The cap is recessed on one side to allow space for the longer AA battery.
6. The attached lanyard will keep the cap from getting lost. Pull up on lanyard to extend length.

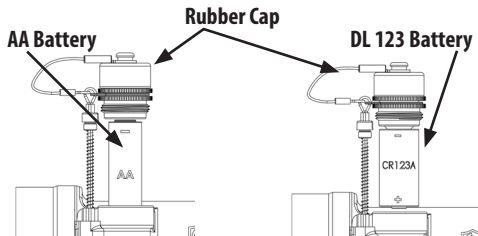
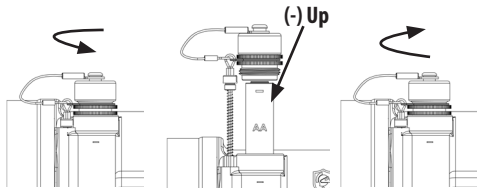

2.3 Installation / Mounting

1. To release (open) the mount lever, push the thumb latch then pull the mount lever to the rear of the scope.
2. Orient the UNS LR-A3 so the larger objective lens points downrange.
3. Locate an installation position where the objective clears any close object, including the rail. Ensure the flat edge of the Rubber Lens Cover, is on the bottom of the objective. The eyepiece should be near the day scope but without the possibility of contacting it.
4. Locate the QD Rail Mount Lever and thumb latch on the right side of the UNS LR-A3 and rotate the lever forward until the thumb latch locks onto the base clamp.

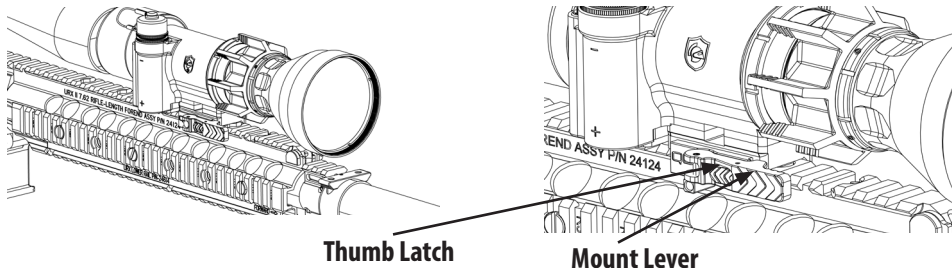

5. Verify that the UNS LR-A3 is securely mounted onto the Picatinny rail. If the fit of the base to the rail is loose or too tight, adjust the base as necessary. See adjustment of QD Rail Mount steps starting on the next page.

6. When properly adjusted, the UNS LR-A3 can be removed and/or installed by only operating the mount lever and thumb latch. Repeat the Adjustment of QD Rail Mount Steps as necessary to achieve a secure and tight fit on the Picatinny rail. Test fire to check for adjustment and point-of-impact shift.

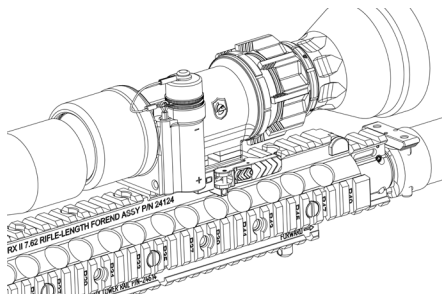

2.4 Adjustment of QD Rail Mount



NOTE: The sight should fit all MIL-STD-1913, or STANAG 4694, rails that are within the manufacturing tolerances, when the base is adjusted properly.

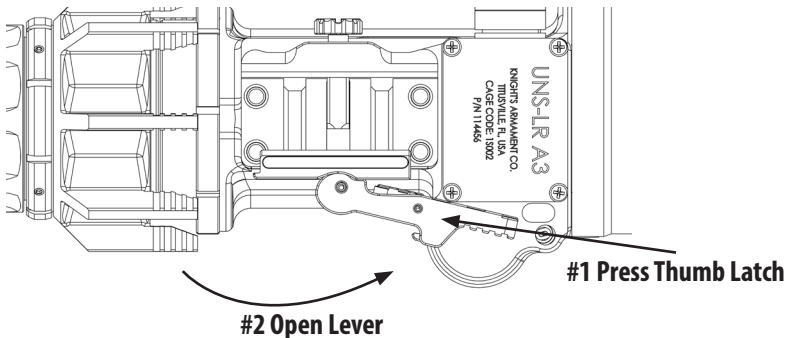

1. For proper base adjustment, open the mount lever by pressing the thumb latch and rotating the lever toward the rear of the sight.

2. Push the lever in to expose the head of the adjustment screw from its locked position.

3. Using your fingers or the 1/8" hex key, loosen, or tighten, the adjustment screw as needed.

4. Install the sight on the rail to check if further adjustment is needed.

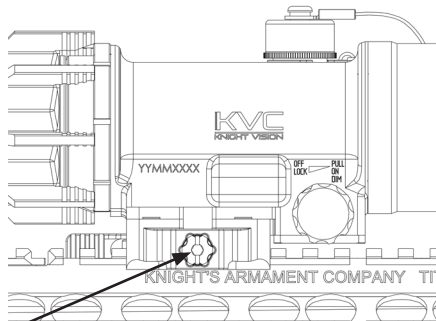

1/8" Hex Key

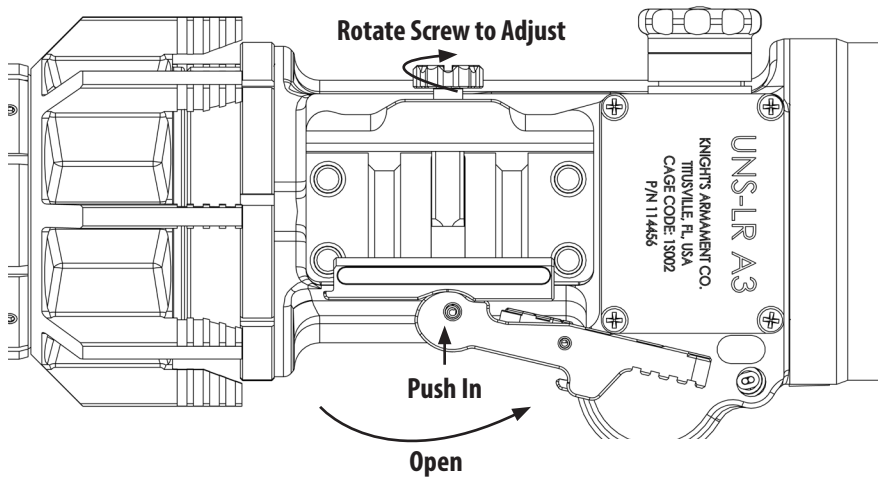



CAUTION



Possible lens breakage and failure of mission can occur if the UNS LR-A3 objective (front) lens makes contact with the flip-up sight during firing or if the eyepiece impacts the day scope .

Position of the objective Rubber Lens Cover, so the flat edge is on the bottom if the UNS LR-A3 is positioned above a rail.

Properly align sight in relation to the flip-up sight on the weapon.

Do not mount the sight in a position that makes it contact with a flip-up sight or any object.

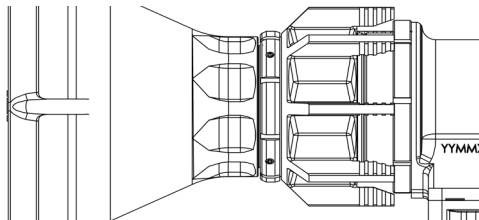
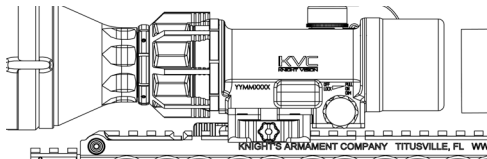

2.5 Installing Shroud Wrap Coupler

The shroud wrap coupler is a neoprene wrap that wraps tightly on the rear lens of the UNS LR-A3 and the objective lens of the day scope.

The shroud wrap coupler fills the gap between the optical scopes and eliminates the stray light which reflects onto or out from the system when the UNS LR-A3 is powered on.

Lay the shroud wrap coupler open under the gap (between the day scope and the UNS LR-A3) with the logo facing up. Wrap the non-Velcro® side around first. Then wrap the Velcro® end around tightly for a snug closure.

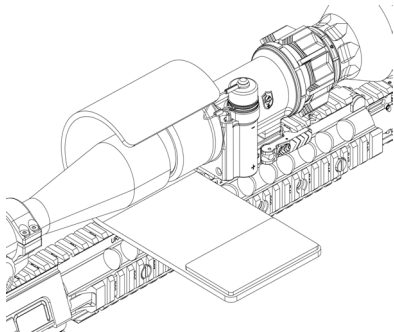

3. PRINCIPLES OF OPERATION

3.1 General

The UNS LR-A3 is constructed of a system of lenses combined with an image intensifier tube. This produces a light intensified image of the viewed scene. This chapter describes the optical and electrical principles of operation, which allow the UNS LR-A3 to perform this function.

3.2 Optical Principle of Operation

The UNS LR-A3 is an electro-optical device providing a system magnification of 1X. The sight is comprised of three basic components: the objective lens assembly, the image intensifier tube, and the eyepiece lens assembly. The objective lens assembly collects available light from the scene being viewed and focuses it onto the front surface of the image intensifier tube. The image tube amplifies the light; it is then viewed by the eyepiece assembly. The interior of the sight is sealed in a nitrogen atmosphere to keep moisture out and prevent condensation on the lenses and the image tube assembly.



Do not remove the front lens cover in bright light. Exposure of the image intensifier tube in the UNS LR-A3 to bright light for long durations may cause permanent damage.

3.3 Electrical Principle of Operation

The entire UNS LR-A3 system is powered by one AA or one DL123 battery that will provide over 36 hours of continuous use, at 23 degrees Centigrade. Battery life is shorter at low temperatures. If the display starts to blink, then change the battery. One switch controls the on/off function as well as the variable gain setting.



WARNING



Do not store batteries in the sight for more than 24 hours. All batteries should be inspected for bulging, corrosion and leakage before use. Do not use if a battery shows signs of bulging, corrosion, or leakage.

Batteries should be handled in the following manner.

- Do not dispose of in fire.
- Do not short circuit, puncture, or disassemble.
- Return for disposal in accordance with proper disposal instructions.



CAUTION



Do not point the UNS LR-A3 at bright lights without the lens cover in place. Remove the lens cover when preparing to use. The unit cannot be used with the lens cover on the objective lens.

4. OPERATING INSTRUCTIONS

4.1 Controls

4.2 Gain/Power Switch

To operate the UNS LR-A3, turn the unit on by pulling out and rotating the Gain/Power Switch clockwise toward the butt stock.

When the UNS LR-A3 is initially turned on, it is at the brightest gain. Turning the knob further clockwise makes the image darker.

To make the image brighter, turn the knob counterclockwise. Utilize the gain switch to obtain the maximum contrast, which is very instrumental in the target acquisition phase of deploying the UNS LR-A3.

To shut down the system, turn the Gain/Power Switch counterclockwise to the stop. A tactile click can be felt when turning the system on or off.

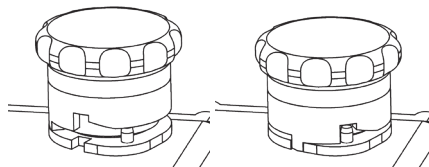
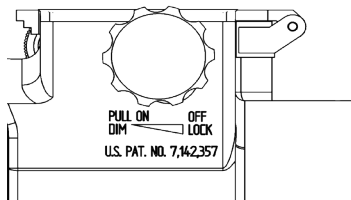

Gain/Power Switch
Pulled Out And Turned On

Gain/Power Switch
Turned OFF

4.3 Focus Ring

The Focus Ring is located on the objective housing forward of the main housing of the unit. The focus can be adjusted to allow viewing of objects at distances from 20 meters to infinity. Clockwise movement will result in infinity focus, while counterclockwise rotation will result in near focus.

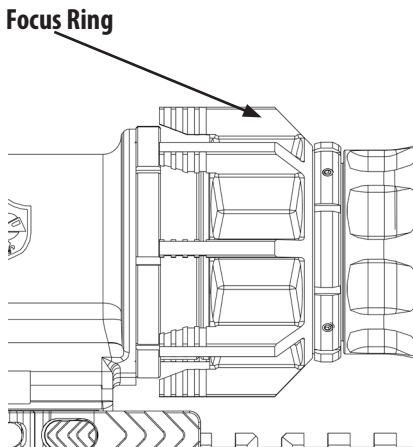

4.4 Operation Under Adverse Conditions

The following paragraph describes the operation of the UNS LR-A3 in dusty, sandy, humid and saltwater conditions. Keep the unit in its protective soft carrying case whenever possible.

4.5 Operation in Dusty or Sandy Conditions

Operating the UNS LR-A3 in these conditions can cause scratching and pitting of optical elements. If a mission requires the UNS LR-A3 be used in these conditions, the unit should be cleaned per the manual as soon as the conditions subside.

4.6 Operation in Rainy or Humid Conditions

Operation in these conditions can lead to corrosion and deterioration of performance. If a mission requires the UNS LR-A3 to be used in these conditions, the unit should be dried thoroughly before storage, and the unit should not be stored wet or in a wet soft carrying case (pouch).

4.7 Operation In Saltwater Areas

If the UNS LR-A3 is exposed to salt water, the unit should be rinsed in fresh water as soon as possible.

5. Handling Instructions

The UNS LR-A3 is a precision optical instrument and must be handled with care. It is designed to handle extreme weapon shock through the mounting rails only. Dropping the unit will expose it to shock loads in axis not intended, and can result in damage to the unit. Dropping the unit on hard surfaces can also result in damage to lens, protective coatings and controls.

Avoid touching the optical surface. The oils from human fingerprints can cause a long-term damaging effect to the lens and their coatings.

The unit is designed to sustain its seal in 3 feet of salt water. Avoid submerging the unit in more than 3 feet of water for long periods. Units can be certified for 66 feet immersion (optional).

Do not attempt to make any adjustments other than those described in this manual. Focus and gain controls are well explained. Adjustment of the QD Rail Mount to accommodate mounting rails is explained. All other adjustments are made at the factory and can only be evaluated and adjusted at the factory.

5.1 STORAGE

If this unit will be stored and not operated for longer than 24 hours, the batteries should be removed to minimize the possibility of damage from defective or corroded batteries.



WARNING



To avoid physical and equipment damage when using the UNS LR-A3 during night operations, carefully read and understand the following precautions:

- The equipment requires some night light (moonlight, starlight, sky glow, etc.) to operate. The level of performance depends upon the level of light.
- Night light is reduced by passing cloud cover or while operating under trees, in building shadows, etc.
- The equipment is less effective when viewing into shadows and other darkened areas.
- The equipment has degraded function through rain, fog sleet, snow or smoke.

6. MAINTENANCE AND SERVICING INSTRUCTIONS

6.1 CLEANING AND LUBRICATION INSTRUCTIONS

These cleaning processes should be followed after every use to ensure the unit is cleaned and lubricated before storage.

6.2 Non-optical Surfaces

These areas can be cleaned with water and a mild detergent as needed.



Rinse optical surfaces with clean water to remove dirt before wiping with lens tissue. Wiping extremely dirty or sandy optical surfaces could scratch the optical surfaces and damage the lenses.

6.3 Optical Surfaces

The optical surfaces should be cleaned when visibly dirty. Blow on the lens to remove sand and dust particles from the surface before cleaning. The optical surfaces can be cleaned with a soft cloth or the cleaning tissues that are provided.

6.4 Lubrication

Moving parts of the Extended Base Assembly can be lubricated using Break-Free® CLP or another similar oil.

6.5 Troubleshooting

If the sight fails to function after the unit has been installed properly on the rail, the following actions should be taken to correct the problem:

- A. Remove front lens cover.
- B. Replace the battery.
- C. Verify that the battery is installed in the proper orientation as referenced in Section 2.
- D. Check the unit for obvious damage.

6.6 Preparation for Shipment

The unit should be packed in the soft carrying case (pouch) with batteries removed, and then securely packaged in a cardboard box with packing material. The box should be marked "FRAGILE" before shipping.

7. SPARE PARTS LIST

7.1 UNS LR-A3 SPARE PARTS

ITEM NO.	PART NO.	DESCRIPTION
1	NVD-UM-0016	TECHNICAL MANUAL, UNS LR-A3
2	23228	WRENCH, HEY KEY, 1-8 IN
3	117570	OBJECTIVE COVER, UNS LR-A3
4	26546	SHROUD, EYEPIECE
5	26572	LENS CLEANING KIT
6	26354	ANTI-REFLECTION ASSY LR, BLK
7	26188	SHROUD WRAP, BLACK
8	26187	SCOPE POUCH, GEN III, MOLLE, BLK
9	27337-1	RETRACTABLE LANYARD ASSY, BLK
10	27361	RUBBER COVER, BATTERY CAP, BLK
11	118990	HYBRID RAIL MOUNT ASSY, UNS LR-A3, BLK



KVC
KNIGHT VISION

ITAR
International Traffic in Arms Regulations

RESTRICTED EXPORT. The item(s) are firearm or defense related goods governed by U.S. Government International Traffic in Arms Regulations 22 CFR, ITAR Parts 120-130 and therefore require an Export License issued by the U.S. Department of State to be subsequently transported outside of the United States. These items may not be transferred, transhipped on a non-continuous voyage, or otherwise be disposed of in any other country, either in their original form or after being incorporated into other end items. The International Traffic in Arms Regulations (ITAR) is a set of United States government regulations that control the export of defense-related articles and services on the United States Munitions List. These regulations implement the provisions of the Arms Export Control Act, and are described in Title 22 (Foreign Relations), Chapter (Department of State), Sub chapter M of the Code of Federal Regulations.